

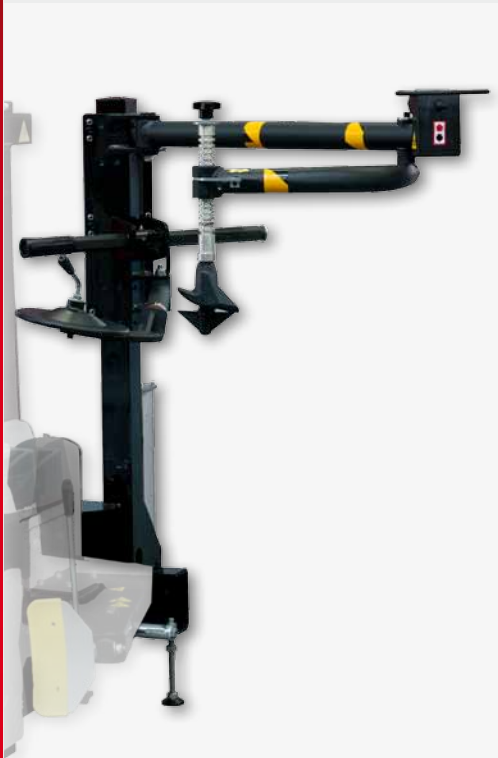

324

Service **PRO**



*HTB24 - helper optional - helper a petición
code 8-11900260



Automatic tyre changer for cars, **lightweight transport vehicles and motor vehicles**



Desmontadora de neumáticos automática para vehículos, **transporte ligero, motos y scooters**



TECHNICAL DATA - DATOS TÉCNICOS

Outside Clamp	<i>Toma externa</i>	11" - 24"
Inside Clamp	<i>Toma interna</i>	13" - 26"
Max. wheel diameter	<i>Diámetro máx. rueda</i>	1100 mm / 43.3"
Tire Width	<i>Ancho neumático</i>	3" - 14"
Bead-breaker opening	<i>Apertura destalonador</i>	380 mm / 15"
Bead-breaking power	<i>Potencia destalonado</i>	15000 N / 3372 lbf
Working air Pressure	<i>Presión de funcionamiento aire</i>	8 - 10 bar / 116 - 145 psi
Motor Power	<i>Potencia motor</i>	0,85 kW - 1.1 kW / 1.1 hp - 1.47 hp
Chuck rotation speed	<i>Velocidad rotación mandril</i>	7 rpm - 2V 6.5 -13 rpm
Noise level running	<i>Ruido durante el funcionamiento</i>	<70 dB
Nett Weight machine	<i>Peso neto máquina</i>	255 kg / 562 lbs
Gross Weight machine	<i>Peso bruto máquina</i>	295 kg / 650 lbs
Max Dimension Imballage (LxPxH) for 40" container	<i>Dimensión máx. embalaje (LxPxH) para contenedor de 40"</i>	1150x920x1000 mm / 45 x 36 x 40" 46 pcs

EQUIPMENT - DOTACIÓN

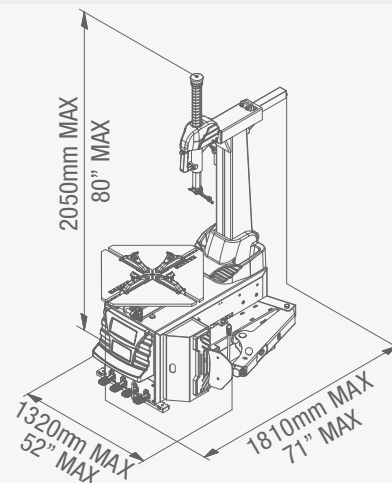

RECOMMENDED ACCESSORIES - ACCESORIOS RECOMENDADOS

- A** **CT-S-0200000**
Plastic bead pressing clamp
Pinza prensa talón de plástico
- B** **801250309**
Plastic MD Head Kit
Kit de cabeza de plástico
- C** **C-M-0200000**
Motorcycle adaptor (hand roller style),
for inner adjustable jaw system use
*Adaptador motocicleta (estilo rodillo manual),
para uso con sistema de garras interno regulable*



For further information, consult the complete accessories catalogue - Para obtener más información, consultar el catálogo de accesorios completo

CORGI Usa Inc.

6067 Schumacher Park Dr West Chester, OH 45069

Local number (513) 874-5958 - Toll free 1-800-260-0968 - www.corghiusa.us - e-mail: info@corghiusa.us



The manufacturer reserves the right to modify the features of its products at any time. For characteristics and technical data, please refer to the previous issue. - DPC0001087 01/2020

Per aiutare il pianeta ottimizzando il consumo di carta, i nostri cataloghi sono consultabili sul sito www.corghiusa.com. Una stampa responsabile aiuta a preservare l'ambiente. To protect the planet and reduce paper usage, our catalogues are viewable online at the website www.corghiusa.com. Printing responsibly contributes to saving the environment.

